

[HTTPS://PCIPY.CO.ZA](https://pcipy.co.za)

PCI

PYRAMID CONTROL INSTRUMENT

We Cater for Customisation



MULTIFUNCTION TRANSDUCER iMT540

- VOLTAGE AND CURRENT AUTO RANGE MEASUREMENTS UP TO **600 V_±**, **12.5 A**.
- **WIDE MEASUREMENT FREQUENCY RANGE** 16 HZ – 400 HZ.
- POWER ACCURACY CLASS **0.2** (IEC-688), 0.1 ON COMMUNICATION.
- UP TO **THREE COMMUNICATION PORTS**.
- **REMOTE DISPLAY iRD500**.
- UP TO **FOUR I/O MODULES**.
- POWERFUL ANALOGUE OUTPUT; 6 VOLTAGE AND CURRENT RANGES, NON-LINEAR CHARACTERISTICS.

FEATURES

- Measurements of instantaneous values of more than 140 quantities (U, I, P, Q, S, PF, PA, f, φ, THD, MD, energy, energy cost by tariffs, etc.).
- Power accuracy class 0.2.
- Harmonic analysis of phase, phase-to-phase voltages and currents up to the 31st harmonic.
- Measurements of 40 minimal and maximal values in different time periods.
- 32 adjustable alarms.
- Frequency range from 16 Hz to 400 Hz.
- Up to three communication ports (RS232/RS485 up to 115,200 bit/s, Ethernet and USB communication).
- MODBUS and DNP3 communication protocols.
- Remote display connection.
- Up to 4 inputs or outputs (analogue inputs/outputs, digital inputs/outputs, alarm/watchdog outputs, pulse input/outputs, tariff inputs).
- Universal power supply (two voltage ranges).
- Automatic range of nominal current and voltage (max. 12.5 A and 600 V_{L-N}).
- Adjustable tariff clock, display of electric energy consumption in selected currency.
- Housing for DIN rail mounting.
- User-friendly setting software, MiQen and WEB server.

DESCRIPTION

The iMT540 are intended for measuring and monitoring single-phase or three-phase electrical power network. They measure TRMS value by means of fast sampling of voltage and current signals, which makes instruments suitable for acquisition of transient events. A built-in microcontroller calculates measurands (voltage, current, frequency, energy, power, power factor, THD phase angles, etc.) from the measured signals.

COMPLIANCE WITH STANDARDS

Standard EN	Description
61010-1:2010	Safety requirements for electrical equipment for measurement, control and laboratory use
60688:2013	Electrical measuring transducers for converting AC electrical variables into analogue and digital signals
61326-1:2013	EMC requirements for electrical equipment for measurement, control and laboratory use - Part 1: General requirements
60529:1997/A1:2000	Degrees of protection provided by enclosures (IP code)
60 068-2-1/ -2/ -6/-27/-30	Environmental testing (-1 Cold, -2 Dry heat, -30 Damp heat, -6 Vibration, -27 Shock)
UL 94	Tests for flammability of plastic materials for parts in devices and appliances

APPLICATION

The iMT540 multifunction transducer is used for measuring and monitoring of all single-phase or three-phase values. Wide range of various I/O modules makes iMT540 a perfect choice for numerous applications. iMT540 can be delivered pre-configured to the required measuring set-up and output characteristic or it can be delivered un-configured for customer configuration with user friendly setting software MiQen. iMT540 supports a wide range of communication interfaces. Standard serial RS232/485 with speed up to 115200 baud is perfect for simple applications and serial bus interfacing. Ethernet 10/100 is ideal for a long distance monitoring and configuration of numerous transducers. USB 2.0 can be used for a fast set-up or memory acquisition.

Pulse inputs are suitable for reading consumption counters (water, gas, heat, compressed air...) and displaying that consumption in primary values.

In combination with analogue extender EX104 it is possible to support up to 7 analogue outputs.

In combination with remote display iRD500 it is possible to remotely monitor readings and make settings of up to 32 in a network connected transducers.

TECHNICAL DATA

Rail mounting according DIN EN60715.

Measurement input:

- Nominal frequency range 50 Hz, 60 Hz
- Measuring frequency range 16 Hz–400 Hz (max. 1000 Hz)

Current measurements:

- Nominal value (I_N) 0.31 A...5 A
- Max. measured value 12.5 A sinusoidal
- Max. allowed value (thermal) 15 A cont.
- (acc. to IEC/EN 60 688) $20 \times I_N$; 5×1 s
- Consumption $< I^2 \times 0.01 \Omega$ per phase

Voltage measurements:

- Nominal value (U_N) 57.7 V_{LN} ...500 V_{LN}
- Max. measured value (cont.) 600 V_{LN} ; 1000 V_{LL}
- Max. allowed value $2 \times U_N$; 10 s
- (acc. to IEC/EN 60 688)
- Consumption $< U^2 / 4.2 M \Omega$ per phase
- Input impedance 4.2 M Ω per phase

System:

Voltage inputs can be connected either directly to low-voltage network or via a high-voltage transformer to high-voltage network.

Current inputs can be connected either directly to low-voltage network or shall be connected to network via a corresponding current transformer (with standard 1 A or 5 A outputs).

BASIC ACCURACY UNDER REFERENCE CONDITIONS

Total accuracy (measurements and analogue output) according to IEC/EN 60 688.

Accuracy is presented as percentage of reading of the measurand except when it is stated as an absolute value.

Measurand	Accuracy ($\pm\%$ of reading)	
Current Trms	0.2	0.05 ⁽¹⁾
Voltage Trms P-N and P-P	0.2	0.05 ⁽¹⁾
Power (P, Q, S)	0.2	0.1 ⁽¹⁾
Power factor (PF)	0.1	
Frequency (f)	10 mHz	
P-N and P-P angle	0.1°	
THD (U), THD (I) (0...400) %	0.5	
Active energy	Class 1	0.5S ⁽²⁾
Reactive energy	Class 2	
Real time clock (RTC)	1 min/month	

⁽¹⁾ On communication

⁽²⁾ Optional

COMMUNICATION

The iMT540 has a wide variety of communication possibilities to suit specific demands. It is equipped with three standard communication ports (COM1A, COM1B, COM1C) and one optional (COM2). This allows up to four different users to access data from a device simultaneously and by using ethernet communication, data can be accessed worldwide.

Different configurations are possible (to be specified with order).

Configuration	COM1A	COM1B	COM1C	COM2 ⁽¹⁾
1	RS232/485 ⁽²⁾	/	/	/
2	RS232/485 ⁽²⁾	/	/	RS485
3	Ethernet	USB	RS485	/
4	Ethernet	USB	RS485	RS485

⁽¹⁾ COM2 uses connection terminals of I/O4 module in case of secondary communication (RS485 only) or RJ11 connector in case of remote display communication

⁽²⁾ RS485 communication is available through DB9 or screw-in terminals, while RS232 is available only through DB9

Serial communication:	RS232⁽¹⁾	RS485⁽¹⁾⁽²⁾
Connection type	Direct	Network
Connection terminals	DB9 ⁽¹⁾	screw terminals ⁽¹⁾
Function	Settings, measurements and records acquisition, firmware upgrade	
Insulation	Protection class I, 3.3 kV _{ACRMS} 1 min	
Max. connection length	3 m	1000 m
Transfer mode	Asynchronous	
Protocol	MODBUS RTU, DNP3 (autodetect)	
Transfer rate	2.4 kBaud to 115.2 kBaud	
Number of bus stations	/	≤32

⁽¹⁾ Both types of comm. are available but only one at a time

⁽²⁾ Specifications are identical for COM2

Ethernet:

Connection type	Network
Connection terminals	RJ-45
Function	Settings, measurements and records acquisition, firmware upgrade
Insulation	Protection class I, 3.3 kV _{ACTRMS} 1 min
Transfer mode	Asynchronous
Protocol	MODBUS TCP, DNP3 (autodetect)
Transfer rate	10/100 Mb/s autodetect

USB:

Connection type	Direct
Connection terminals	USB-B
Function	Settings, measurements and records acquisition, firmware upgrade
Insulation	Protection class I, 3.3 kV _{ACTRMS} 1 min
Transfer mode	Asynchronous
Protocol	MODBUS RTU, DNP3 (autodetect)
Transfer rate	USB 2.0

REMOTE DISPLAY

Remote display iRD500 is very useful for a quick look-up to all measured parameters or to set up the iMT540 measuring transducers without the PC. Navigation keys and graphical LCD display enable remote application and remote display settings. By choosing different iRD500 target communication addresses it is possible to track measurements and change settings for up to 32 iMT540 measuring transducers.

Connection of remote display iRD500 depends on application:

- **DIRRECT CONNECTION TO A SINGLE iMT540**

This type of connection is useful for instant measurement and waveform acquisition as well as adjusting settings of a single iMT540 by using a quick access RJ11 jack (under the transparent cover).

- **BUS CONNECTION TO MULTIPLE iMT540**

This type of connection is useful for a remote monitoring and adjusting settings of multiple (up to 32) iMT540 attached to a RS485 bus through COM1 or COM2 (if available) communication port. To access each individual iMT540, the user should enter an address of required iMT540.

For more information about connection, and using of remote display see User's manual.



INPUT/OUTPUT MODULES

iMT540 is equipped with 4 multipurpose input/output slots. The following modules are available:

Analogue input	4 inputs	any I/O
Analogue output	4 outputs	any I/O
Digital input	4 inputs	any I/O
Alarm/Relay output	4 outputs	any I/O
Pulse input	4 inputs	any I/O
Pulse/Digital output	4 outputs	any I/O
Watchdog output	4 outputs	any I/O
Tariff input	2 inputs	I/O 1,2
Additional comm. port (COM2)*	1 I/O	I/O 4

*See page 4 (serial communication)

Analogue input:

Three types of analogue inputs are suitable for acquisition of low voltage DC signals from different sensors. According to application requirements it is possible to choose current, voltage or resistance (temperature) analogue input. They all use the same output terminals.

MiQen software allows setting an appropriate calculation factor, exponent and required unit for representation of primary measured value (temperature, pressure, flux, etc.).

DC current input:

Nominal input range	-20 mA - 20 mA ($\pm 20\%$)
input resistance	20 Ω
accuracy	0.5 % of range
conversion resolution	16 bit (sigma-delta)
Analogue input mode	internally referenced Single-ended

DC voltage input:

Nominal input range	-10 V - 10 V ($\pm 20\%$)
input resistance	100 k Ω
accuracy	0.5 % of range
conversion resolution	16 bit (sigma-delta)
Analogue input mode	internally referenced Single-ended

Resistance (temperature) input:

Nominal input range (low)*	(0 – 200) Ω (max. 400 Ω)
	PT100 (-200°C–850°C)
Nominal input range (high)*	(0 – 2) k Ω (max. 4 k Ω)
	PT1000 (-200°C–850°C)
connection	2-wire
accuracy	0.5 % of range
conversion resolution	16 bit (sigma-delta)
Analogue input mode	internally referenced Single-ended

*** Low or high input range and primary input value (resistance or temperature) are set by the MiQen setting software**

Analogue output:

Each of up to four analogue outputs is fully programmable and can be set to any of 6 full-scale ranges, 4 current and 2 voltage, without opening an instrument. They all use the same output terminals.

Programmable DC current output:

Output range values	-100 %...0...100 %
(-1...0...1) mA	Range 1
(-5...0...5) mA	Range 2
(-10...0...10) mA	Range 3
(-20...0...20) mA	Range 4
other ranges possible	Sub range
Burden voltage	10 V
External resistance	$R_{Bmax} = 10 V / I_{outN}$

Programmable DC voltage output:

Output range values –100 %...0...100 %

(-1...0...1) V	Range 5
(-10...0...10) V	Range 6
other ranges possible	Sub range
Burden current	5 mA
External resistance	$R_{Bmin} = U_{outN}/5 \text{ mA}$

General:

Linearization	Linear, Quadratic
No. of break points	5
Output value limits	$\pm 120\%$ of nominal output
Response time (measurement and analogue output)	< 100 ms
Residual ripple	< 0.5 % p.p.

The outputs 1 to 4 may be either short or open-circuited. They are electrically insulated from each other (500 VACrms) and from all other circuits (3320 VACrms).

All output range values can be altered subsequently (zoom scale) using the setting software, but a supplementary error results (see INTRINSIC ERROR).

Digital input

Rated voltage	48 V AC/DC (+ 40% max)
Max. current	< 1.5 mA
Min. signal width	20 ms
Min. pause width	40 ms
SET voltage	40 %...120 % of rated voltage
RESET voltage	0 %...10 % of rated voltage

Alarm (digital) output:

Type	Relay switch
Rated voltage	48 V AC/DC (+40% max)
Max. switching current	1000 mA
Contact resistance	$\leq 100 \text{ m}\Omega$ (100 mA, 24 V)
Impulse	Max. 4000 imp/hour Min. length 100 ms
Insulation voltage	
Between coil and contact	4000 VDC
Between contacts	1000 VDC

Pulse input

Rated voltage	5 V- 48 V DC ($\pm 20\%$)
Max. current	8 mA (at 48 VDC + 20%)
Min. pulse width	0.5 ms
Min. pulse periode	2 ms

SET voltage	40 %...120 % of rated voltage
RESET voltage	0 %...10 % of rated voltage

Pulse (digital) output

Type	Solid state
Max. voltage	40 V AC/DC
Max. current	30 mA ($R_{ONmax} = 8\Omega$)
Pulse length	programmable 1 ms...999 ms

Tariff input

Rated voltage	230 VAC or 110 VAC $\pm 20\%$
Max. current	< 0.6 mA
Frequency range	45 Hz...65 Hz
SET voltage	40 %...120 % of rated voltage
RESET voltage	0 %...10 % of rated voltage

Watchdog (status) output

Type	Relay switch
Normal operation	Relay in ON position
Failure detection delay	$\approx 1.5 \text{ s}$
Rated voltage	48 V AC/DC (+40 % max)
Max. switching current	1000 mA
Contact resistance	$\leq 100 \text{ m}\Omega$ (100 mA, 24 V)

UNIVERSAL POWER SUPPLY



Standard (high):

Nominal voltage AC	80 V... 276 V
Nominal frequency	40 Hz... 65 Hz
Nominal voltage DC	70 V... 300 V
Consumption	< 8VA
Power-on transient current	< 20 A ; 1 ms

Optional (low):

Nominal voltage AC	48 V... 77 V
Nominal frequency	40 Hz... 65 Hz
Nominal voltage DC	19 V... 70 V
Consumption	< 8 VA
Power-on transient current	< 20 A ; 1 ms

SAFETY:

<p>Protection:</p> <p> </p>	<p>protection class I (protective earth terminal due to touchable metal parts (USB-B, RJ-45, DB9), current limiting fuse 1 A on aux. supply Voltage inputs via high impedance Double insulation for I/O ports and COM1-2 ports</p>
<p>Pollution degree</p>	<p>2</p>
<p>Installation category</p>	<p>CAT III ; 600 V_⊥ meas. inputs CAT III ; 300 V_⊥ aux. supply Acc. to EN 61010-1</p>
<p>Test voltages</p>	<p>UAUX↔I/O, COM1,2: 2210 VACrms UAUX↔U, I inputs: 3320 VACrms U, I inputs↔I/O, COM1,2: 3320 VACrms HV Tariff input↔I/O, COM1,2: 2210 VACrms U inputs↔I inputs: 3320 VACrms</p>
<p>Enclosure material</p>	<p>PC/ABS Acc. to UL 94 V-0</p>
<p>Enclosure protection</p>	<p>IP 40 (IP 20 for terminals)</p>

MECHANICAL

<p>Dimensions(WxHxD)</p>	<p>(100 × 123 × 75) mm</p>
<p>Mounting</p>	<p>Rail mounting (35 × 15) mm acc. to DIN EN 50 022</p>
<p>Enclosure material</p>	<p>PC/ABS, PC (sliding cover)</p>
<p>Flammability</p>	<p>Acc. to UL 94 V-0</p>
<p>Weight</p>	<p>500 g</p>

AMBIENT CONDITIONS:

<p>Ambient temperature</p>	<p>usage group III -10°C...0...45...55 °C Acc. to IEC/EN 60 688</p>
<p>Operating temperature</p>	<p>-30°C to +70°C</p>
<p>Storage temperature</p>	<p>-40°C to +70°C</p>
<p>Average annual humidity</p>	<p>≤ 93% r.h.</p>

REFERENCE CONDITIONS:

<p>Ambient temperature</p>	<p>0°C ...45°C</p>
<p>Relative humidity</p>	<p>≤ 93% r.h.</p>
<p>Voltage input</p>	<p>57.7 V...500 V</p>
<p>Current input</p>	<p>0.31 A...5 A</p>
<p>Frequency</p>	<p>45 Hz...65 Hz</p>
<p>Active/Reactive power factor</p>	<p>cosφ = 1, sinφ = 1</p>
<p>Waveform</p>	<p>Sinus</p>

AUXILIARY BATTERY

A built-in replaceable auxiliary battery enables the clock operation and recording the measurements in the memory with the time stamp. The battery shall be replaced by the authorised service.

<p>Type</p>	<p>CR2032 Li-battery</p>
<p>Nominal voltage</p>	<p>3 V</p>
<p>Life span</p>	<p>approx. 6 years (typical at 23°C)</p>

INTRINSIC-ERROR (FOR ANALOGUE OUTPUTS):

For intrinsic-error for analogue outputs with bent or linear-zoom characteristic multiply accuracy class with correction factor (c). Correction factor c (the highest value applies):

Linear characteristic

$$c = \frac{1 - \frac{y_0}{y_e}}{1 - \frac{x_0}{x_e}} \quad \text{or} \quad c = 1$$

Bent characteristic

$$x_{b-1} \leq x \leq x_b$$

b – number of break point (1 to 5)

$$c = \frac{y_b - y_{b-1}}{x_b - x_{b-1}} \cdot \frac{x_e}{y_e} \quad \text{or} \quad c = 1$$

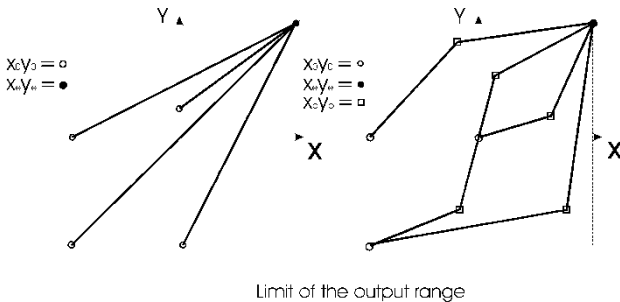

Examples of settings with linear and bent characteristic.

ALARMS

iMT540 supports recording and storing of 32 alarms in four groups. A time constant of maximal values in a thermal mode, a delay time and switch-off hysteresis are defined for each group of alarms.

MIQEN - SETTING AND ACQUISITION SOFTWARE

MiQen software is intended for supervision of iMT540 and many other instruments on a PC. Network and the transducer setting, display of measured and stored values and analysis of stored data in the transducer are possible via the serial, Ethernet or USB communication. The information and stored measurements can be exported in standard Windows formats. Multilingual software functions on Windows 98, 2000, NT, XP operating systems.

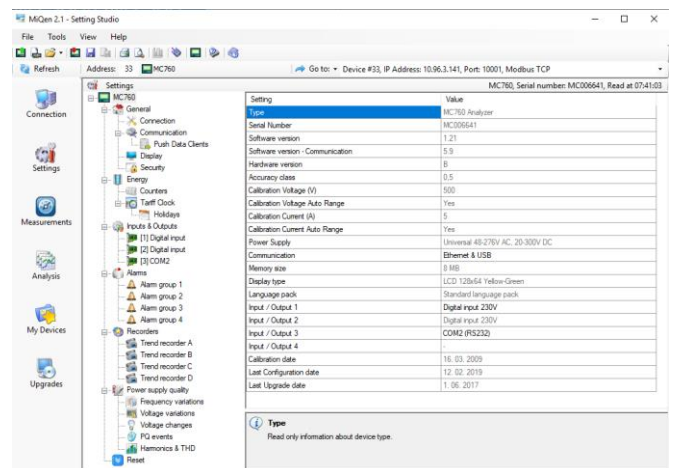

MiQen software is intended for:

- Setting all of the instruments parameters (online and offline).
- Viewing current measured readings.
- Setting and resetting energy counters.
- Complete I/O modules configuration.
- Upgrading instruments firmware.
- Searching the net for devices.
- Virtual interactive instrument.
- Comprehensive help support.

CONNECTION

System/connection	Terminal assignment
Single-phase connection 1b (1W)	
Three-phase three-wire connection with balanced load 3b (1W3)	
Three-phase three-wire connection with unbalanced load 3u (2W3)	

System/ connection

Terminal assignment

Three-phase four wire connection with balanced load

4b (1W4)

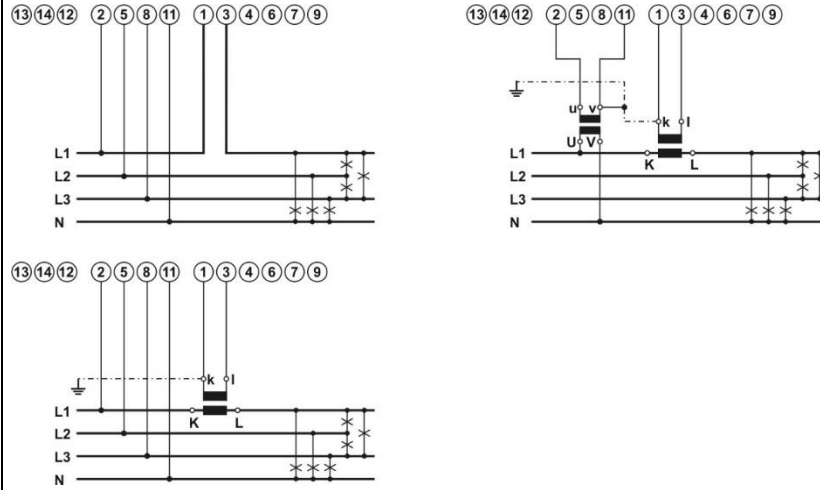

Three-phase four wire connection with unbalanced load

4u (3W4)

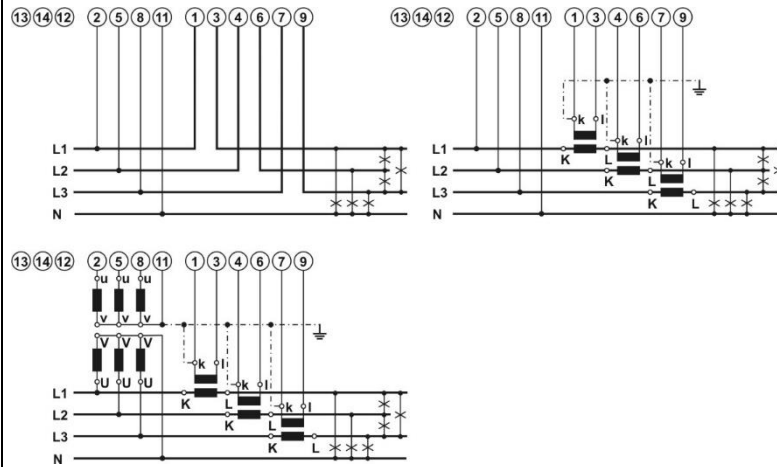

DIMENSIONAL DRAWING

Dimensions for iMT540 (standard EU clamp style terminals):

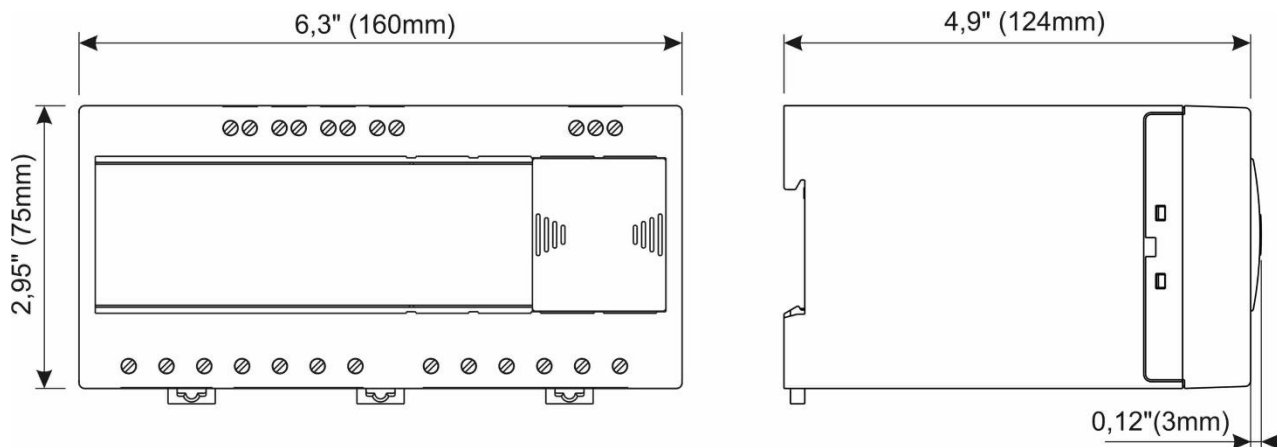

Dimensions for iUMT540 (ring type terminal block):

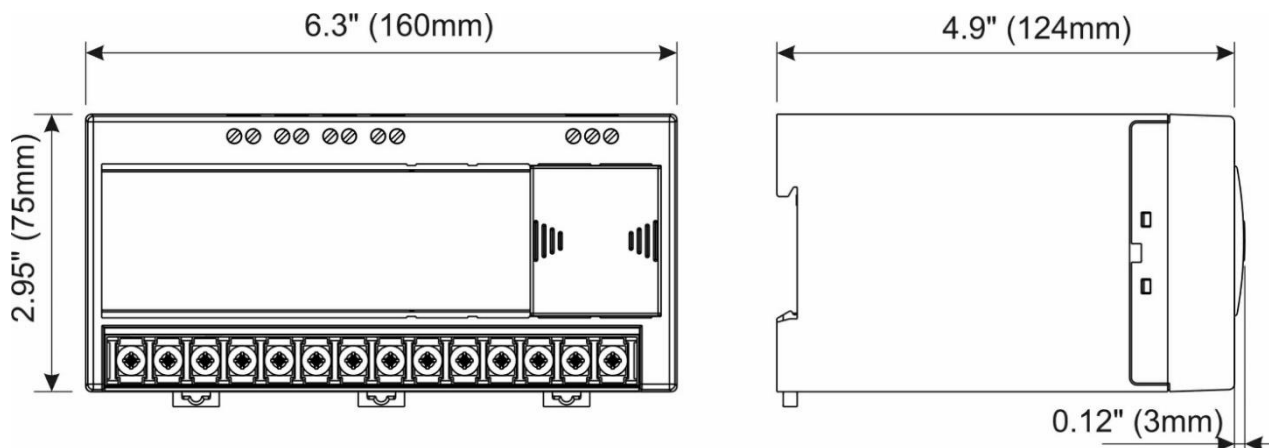

CONNECTION TABLE

Function		Terminals	
Measuring input:	AC current	IL1	1/3
		IL2	4/6
		IL3	7/9
	AC voltage	UL1	2
		UL2	5
		UL3	8
		N	11
		I/O	
Inputs / outputs:	Module 1	⊕ +	15
		⊖ -	16
	Module 2	⊕ +	17
		⊖ -	18
	Module 3	⊕ +	19
		⊖ -	20
	Module 4	⊕ +	21
		⊖ -	22
Auxiliary power supply:	+ / AC (L)		13
	- / AC (N)		14
	GROUND ⊕		12
Communication:	RS485	A	23 [#]
		NC	24 [#]
		B	25 [#]

[#] RS232 communication is available only on DB9 connection terminal under transparent cover

DATA FOR ORDERING

iMT540:

The following data shall be stated:

- Type of a transducer
- Type of power supply
- Type of communication
- Type of I/O module(s)
- Required energy accuracy

Supplement:

MiQen software

ORDERING

When ordering iMT540, all required specifications should be stated in compliance with the ordering code. Additional information could be stated

regarding functionality of analogue outputs. Default settings for analogue outputs provided that no ordering information is given will be:

Analogue output	Input quantity	Output quantity
AO1	$P (-7500...0...7500) W$	$-20...0...20 mA$
AO2	$Q (-7500...0...7500) var$	$-20...0...20 mA$
AO3	$U1 (0...500) V$	$0...20 mA$
AO4	$I1 (0...5) A$	$0...20 mA$

If different analogue output settings are required, a proper input quantity/output quantity pair for each analogue output should be provided.

The transducers automatic range of input current (5 A) and voltage (500 V_{L-N}) is not stated in the code.

Example of ordering:

iMT540 with EU style clamp terminals which has active energy accuracy class 1 and reactive energy accuracy class 2. The transducer with a universal-HI supply is connected to an universal high voltage and 5 A secondary current on 50 Hz network. Ethernet & USB & RS485 communication, two analogue outputs as I/O1 and I/O2 and two pulse outputs as I/O3 and I/O4.

Voltage and current nominal value are due to auto-range fixed to max. nominal value and are therefore omitted from ordering code.

Connection type is user programmable and is therefore omitted from ordering code. Default is 4u connection.

Example ordering code:

iMT540 **S S H F N A A S S E**
 | | | | | | | | | EU style clamp terminals
 | | | | | | | | | Pulse output
 | | | | | | | | | Pulse output
 | | | | | | | | | Analogue output
 | | | | | | | | | Analogue output
 | | | | | No
 | | | Ethernet & USB & RS485
 | | 70 V_{DC}... 300 V_{DC}, 80 V_{AC}... 276 V_{AC}
 | 50 Hz, 60 Hz
 Active cl.1 / Reactive cl.2

GENERAL ORDERING CODE

All specifications are obligatory except function of analogue output(s), which should be stated in a form of description.

Device Type	Energy Accuracy Class	Nominal freq.	Aux. power supply	Comm. COM1	Remote display supp.	I/O module 1	I/O module 2	I/O module 3	I/O module 4	Clamp terminals
iMT540	X	X	X	X	X	X	X	X	X	X
										E EU style clamp terminals *
										R Ring style terminal block
							A			Analogue output*
							S			Pulse output
							M			Relay (alarm) output
							O			HV Relay (alarm) output
							W			Watchdog output
							V			HV Watchdog output
							I			Analogue input - mA _{DC}
							U			Analogue input - V _{DC}
							R			Analogue input - R/Temp.
							P			Pulse input 5 - 48 V _{DC}
							F			Digital input 48 V _{AC/DC}
							T			Tariff input 230 V _{AC} **
							Z			Tariff input 110 V _{AC} **
							C			RS485 Communication - COM2 ***
							X			Output Extender - COM2 ***
							N			Without
					N	No				
					*	*				
					Y	Yes				
				R	RS232 & 485	DB9 + Terminal *				
				F	Ethernet & USB & RS485					
			H	70...300 V _{DC} , 80...276 V _{AC}						
			*	*						
			L	19...70 V _{DC} , 48...77 V _{AC}						
		S	50, 60 Hz *							
		A	400 Hz							
	S	Active cl.1 / Reactive cl.2 *								
	H	Active cl.0.5S / Reactive cl.2								

* - standard

** - I/O module 1 and 2 only.

*** - I/O module 4 only. Not available together with remote display support.

DISPOSAL



It is forbidden to deposit electrical and electronic equipment as municipal waste.

The manufacturer or provider shall take waste equipment free of charge.



DICTIONARY:

<i>RMS</i>	<i>Root Mean Square</i>
<i>TRMS</i>	<i>True Root Mean Square</i>
<i>PO</i>	<i>Pulse output</i>
<i>TI</i>	<i>Tariff input</i>
<i>PA</i>	<i>Power angle (between current and voltage)</i>
<i>PF</i>	<i>Power factor</i>
<i>THD</i>	<i>Total harmonic distortion</i>
<i>Ethernet</i>	<i>IEEE 802.3 data layer protocol</i>
<i>MODBUS/DNP3</i>	<i>Industrial protocol for data transmission</i>
<i>MiQen</i>	<i>ISKRA setting and acquisition Software</i>
<i>AC</i>	<i>Alternating quantity</i>
<i>IR</i>	<i>Infrared (optical) communication</i>